

# 03002 and 03101

## R. M. Young Wind Sentry Set and Anemometer



R. M. Young's 03002 Wind Sentry Set accurately measures wind speed and direction. The 03101 provides just the anemometer for customers who only want wind speed measurements. These sensors interface directly with our dataloggers; no signal conditioning is required. All of our contemporary dataloggers and many of our retired dataloggers (e.g., CR510, CR10X, CR23X) are compatible with the Wind Sentry.

The Wind Sentry uses a three-cup anemometer to measure wind speed. Rotation of the cup wheel produces an ac sine wave that is directly proportional to wind speed. The frequency of the ac signal is measured by a datalogger pulse count channel, then converted to engineering units (mph, m/s, knots). Campbell Scientific's version of the Wind Sentry uses shielded bearings which lowers the anemometer's threshold.

Wind direction is sensed by a potentiometer. With the precision excitation voltage from the datalogger applied to the potentiometer element, the output signal is an analog voltage that is directly proportional to the azimuth angle of the wind direction.

An ideal application for the Wind Sentry is wind profile studies. For this application, the LLAC4 4-channel Low Level AC Conversion Module can be used to increase the number of Wind Sentry Sets measured by one datalogger. The LLAC4 allows datalogger control ports to read the anemometer's ac signals instead of using pulse channels. Dataloggers compatible with the LLAC4 are the CR200(X)-series (ac signal  $\leq 1$  kHz only), CR800, CR850, CR1000, CR3000, and CR5000.

### Mounting

The 03002 is supplied with a 12-in.-long x 1-in. IPS unthreaded aluminum pipe, which mounts to a crossarm via a CM220 Mount or 17953 NU-RAIL fitting. When purchased separately, the 03101 anemometer is supplied with a galvanized 10-in.-long x  $\frac{3}{4}$ -in. IPS threaded pipe, which mounts to a crossarm via a CM220 mount or 1049 NU-RAIL fitting. The 03002 or 03101 can also be mounted to the top of a CM110, CM115, or CM120 stainless-steel tripod via the CM216.



### Ordering Information

#### Wind Sensors

- 03002-L** Wind Sentry Set; enter lead length, in feet, after the -L. A cable termination option is required (see below).
- 03101-L** Wind Sentry Anemometer only; enter lead length, in feet, after the -L. A cable termination option is required (see below).

#### Cable Termination Options (choose one)

- PT** Cable terminates in stripped and tinned leads for direct connection to a datalogger's terminals.
- PW** Cable terminates in a connector for attachment to a prewired enclosure.
- CWS** 03002 cable terminates in a connector for attachment to a CWS900 interface. Connection to a CWS900 interface allows the 03002 to be used in a wireless sensor network. This option is only for the 03002.

#### Mounts

- CM220** Right Angle Mounting Bracket for attaching a 03002 or 03101 to a crossarm, such as a CM202, CM204, or CM206.
- 17953** 1-in. x 1-in. NU-RAIL Fitting for mounting the 03002 Wind Sentry Set to a crossarm, such as a CM202, CM204, or CM206. This mount is for only the 03002 Wind Sentry Set.
- 1049**  $\frac{3}{4}$ -in. x 1-in. NU-RAIL Fitting for mounting just the 03101 anemometer to a crossarm, such as a CM202, CM204, or CM206. This mount is for only the 03101 Wind Sentry Anemometer.
- CM216** Sensor Mounting Kit for attaching the 03002 or 03101 to the top of a CM110, CM115, or CM120 stainless-steel tripod.

### Recommended Cable Lengths

CM6	CM106	CM10	CM110	CM115	CM120	UT10	UT20	UT30
10 ft	13 ft	13 ft	13 ft	19 ft	24 ft	13 ft	24 ft	34 ft

*These cable lengths assume the sensor is mounted atop the tripod/tower via a CM202 crossarm.*

## Specifications

### Wind Sentry Assembly

<b>Operating Temperature:</b>	-50° to +50°C; assuming non-riming conditions
<b>Overall Height:</b>	32 cm (12.6 in.)
<b>Crossarm Length:</b>	40 cm (15.7 in.) between instruments (center-to-center)
<b>Mounting Diameter:</b>	34 mm (1.34 in.); mounts on standard 1-in. IPS pipe

### Wind Speed (Anemometer)

<b>Range:</b>	0 to 50 m s <sup>-1</sup> (112 mph)
<b>Gust Survival:</b>	60 m s <sup>-1</sup> (134 mph)
<b>Sensor:</b>	12-cm diameter cup wheel assembly, 40-mm diameter hemispherical cups
<b>Accuracy:</b>	±0.5 m s <sup>-1</sup> (1.1 mph)
<b>Turning Factor:</b>	75 cm (2.5 ft)
<b>Distance Constant (63% recovery):</b>	2.3 m (7.5 ft)
<b>Threshold:</b>	0.5 m s <sup>-1</sup> (1.1 mph)
<b>Transducer:</b>	Stationary coil; 1300 ohm nominal resistance
<b>Transducer Output:</b>	AC sine-wave signal induced by rotating magnet on cup wheel shaft 100 mV peak-to-peak at 60 rpm; 6 V peak-to-peak at 3600 rpm
<b>Output Frequency:</b>	1 cycle per cup wheel revolution; 0.75 m s <sup>-1</sup> per Hz
<b>Cup Wheel Diameter:</b>	12 cm (4.7 in.)
<b>Weight:</b>	113 g (4 oz)

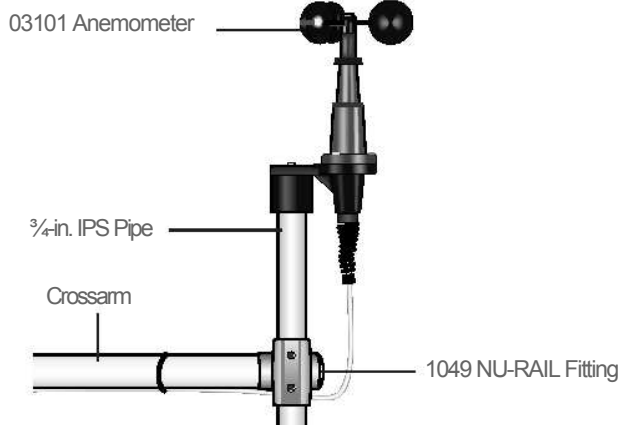

### Wind Direction (Vane)

<b>Range:</b>	360° mechanical; 352° electrical (8° open)
<b>Sensor:</b>	Balanced vane; 16 cm turning radius
<b>Accuracy:</b>	±5°
<b>Damping Ratio:</b>	0.2
<b>Delay Distance (50% recovery):</b>	0.5 m (1.6 ft)
<b>Threshold</b>	
<b>10° Displacement:</b>	0.8 m s <sup>-1</sup> (1.8 mph)
<b>5° Displacement:</b>	1.8 m s <sup>-1</sup> (4 mph)
<b>Transducer:</b>	Precision conductive plastic potentiometer; 10 kohm resistance; 1.0% linearity; life expectancy of 50 million revolutions. Rated 1 Watt at 40°C, 0 Watts at 125°C.
<b>Transducer Excitation:</b>	Requires regulated dc voltage, 15 Vdc maximum
<b>Transducer Output:</b>	Analog dc voltage proportional to wind direction angle with regulated excitation voltage supplied by the datalogger
<b>Vane Length:</b>	22 cm (8.7 inch)
<b>Weight:</b>	170 g (6 oz)

